

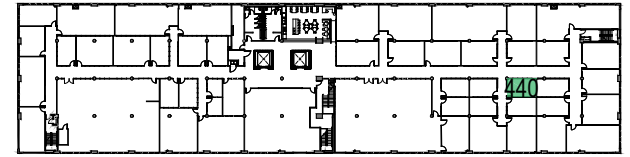

**KEARNY
POINT**

FLOOR PLANS

SPRING 2020



Key Plan

North Arrow

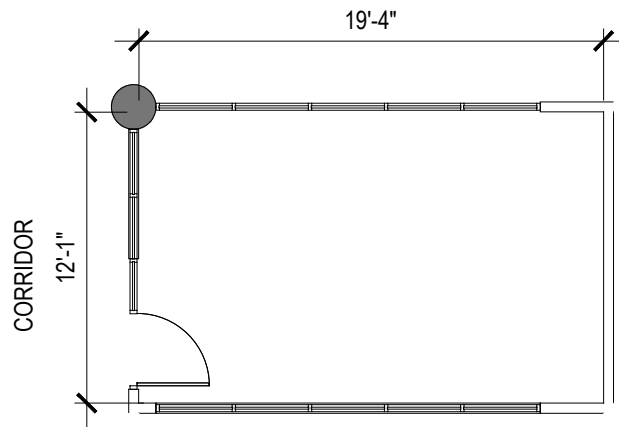

Fourth Floor - Suite 440
235 SF Net / 339 SF Gross

Buchholz Architects
123 Columbia Turnpike Suite 204A
Florham Park, NJ 07932
973.746.0100 Phone
Info@buchholzgroup.com

BUILDING 78 | 78 JOHN MILLER WAY | KEARNY, NJ 07032

Date: 6-Feb-17 Scale: NTS Project Number: 0714-1577

NICK SHEARS
DIRECTOR OF LEASING
HUGO NEU REALTY MANAGEMENT LLC
O: (973) 771-6413 C: (609) 937-2564
FLEX SPACES @ KEARNY POINT



Drawing:
LP-440

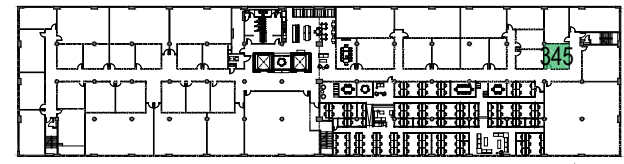
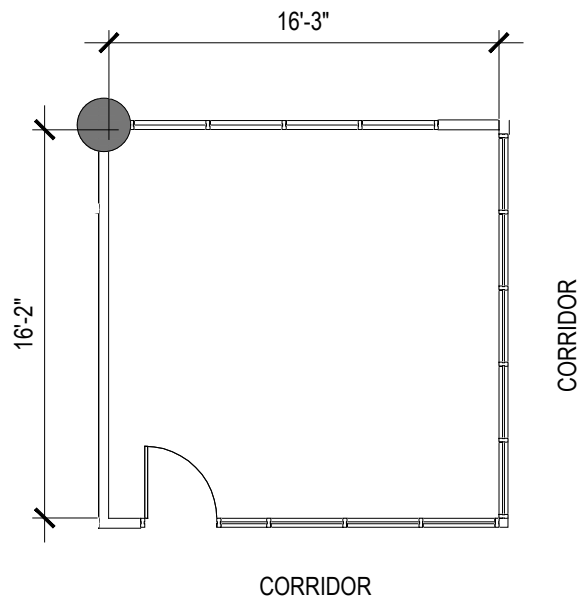

Key Plan

North Arrow

Third Floor - Suite 345
262 SF Net / 364 SF Gross

© 2015 K15177 - 78 John Miller Way Kearny, NJ File: Corridor (PREL) (MANA) (V) (use) (Third Floor) (Third Floor) (03/17) 10331 AM

Buchholz Architects
123 Columbia Turnpike Suite 204A
Florham Park, NJ 07932
973.746.0100 Phone
Info@buchholzgroup.com

BUILDING 78 | 78 JOHN MILLER WAY | KEARNY, NJ 07032

Date: 7-Feb-17 Scale: NTS Project Number: 0714-1577

NICK SHEARS
DIRECTOR OF LEASING
HUGO NEU REALTY MANAGEMENT LLC
O: (973) 771-6413 C: (609) 937-2564
FLEX SPACES @ KEARNY POINT



Drawing: **LP-345**

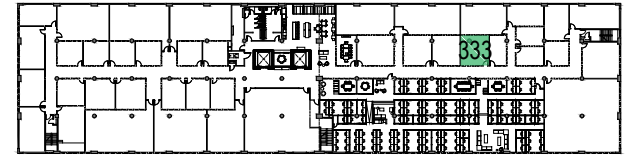
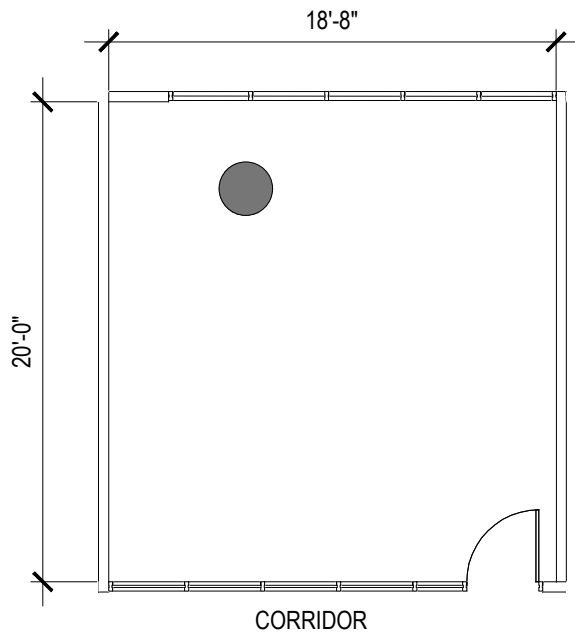

Key Plan

North Arrow

Third Floor - Suite 333
373 SF Net / 518 SF Gross

Buchholz Architects
123 Columbia Turnpike Suite 204A
Florham Park, NJ 07932
973.746.0100 Phone
Info@buchholzgroup.com

BUILDING 78 | 78 JOHN MILLER WAY | KEARNY, NJ 07032

Date: 7-Feb-17 Scale: NTS Project Number: 0714-1577

NICK SHEARS
DIRECTOR OF LEASING
HUGO NEU REALTY MANAGEMENT LLC
O: (973) 771-6413 C: (609) 937-2564
FLEX SPACES @ KEARNY POINT



Drawing:
LP-333

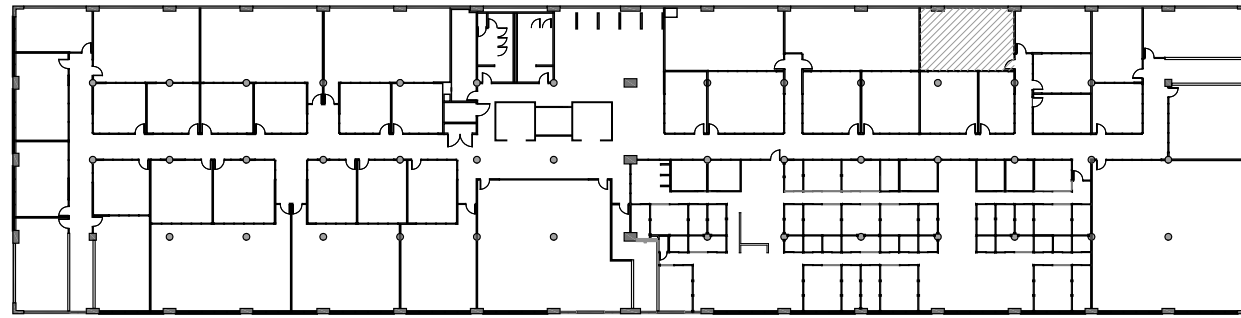

1 Key Plan
1/64" = 1'0"

4x



Eames Chair
Existing

6x



UPPBO Ikea Lamp

9x



Hon Chair
Existing

3x



Ekerö Chair

1x



Billsta Table

2x



Note Side Table

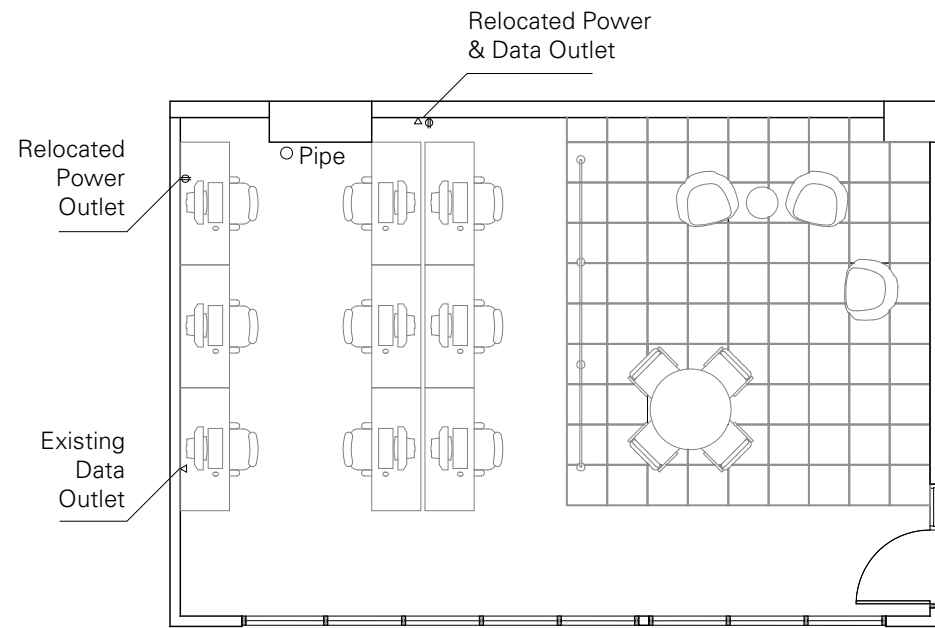

2 Proposed Layout - 343
1/8" = 1'0"

Desks: 9
SQF: 613

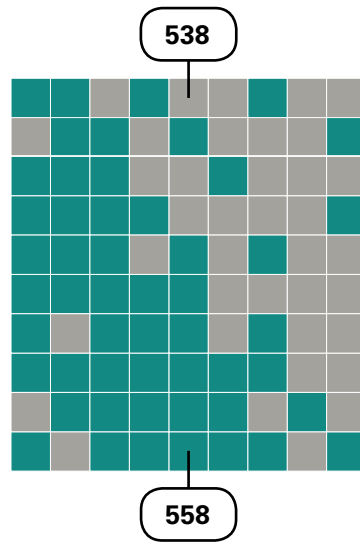

538 Silver Birch 38/38

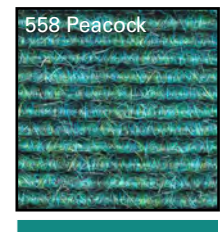

558 Peacock 52/418

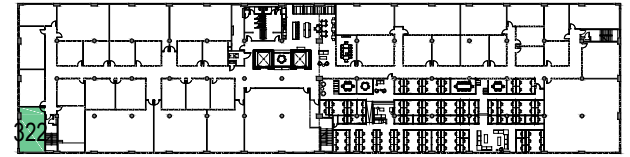
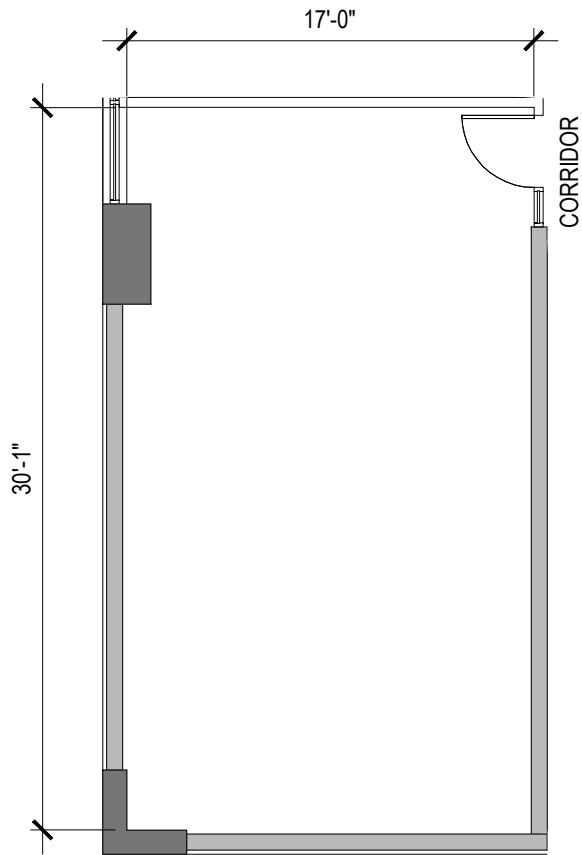

Key Plan



North Arrow

Third Floor - Suite 322
509 SF Net / 707 SF Gross

© 2015 K15177 - 3d Jan Miller/Kearny, NJ File Cabinet/PRELIMINARY/Issue Based/Third Floor/Issue/way - 2/7/2017 10:20 AM

Buchholz Architects
123 Columbia Turnpike Suite 204A
Florham Park, NJ 07932
973.746.0100 Phone
Info@buchholzgroup.com

BUILDING 78 | 78 JOHN MILLER WAY | KEARNY, NJ 07032

Date: 7-Feb-17 Scale: NTS Project Number: 0714-1577

NICK SHEARS
DIRECTOR OF LEASING
HUGO NEU REALTY MANAGEMENT LLC
O: (973) 771-6413 C: (609) 937-2564
FLEX SPACES @ KEARNY POINT



Drawing:
LP-322

KEARNY POINT

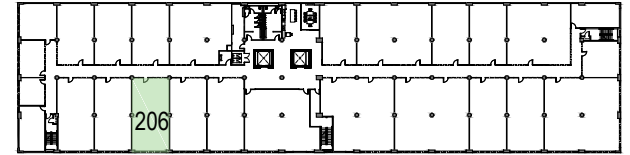
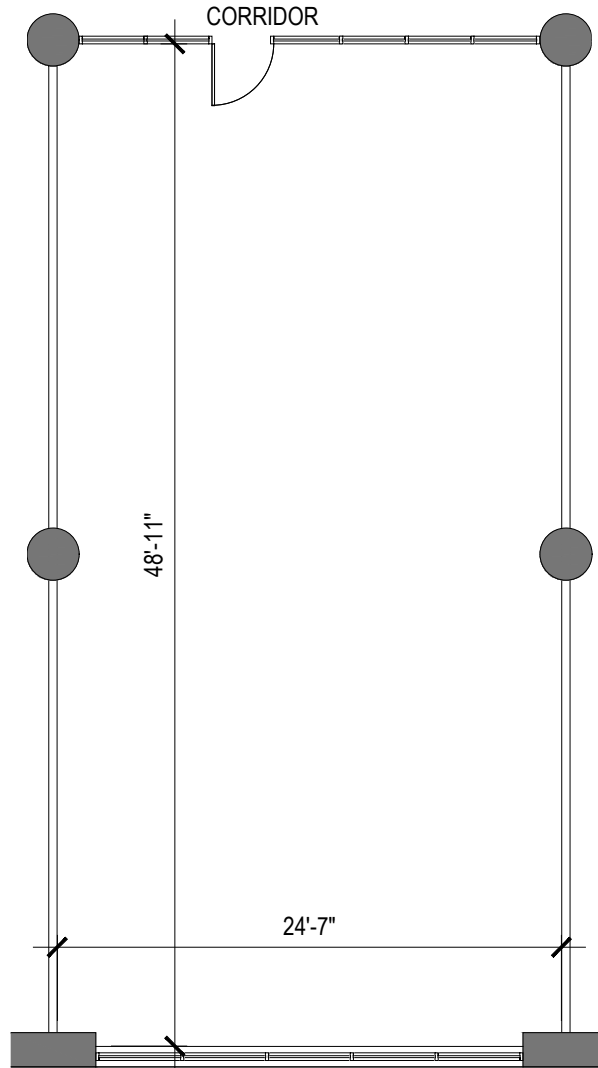

Key Plan

North Arrow

Second Floor - Suite 206
1,196 SF Net / 1,603 SF Gross

© 2015 A15127 - 78 John Miller Way Kearny, NJ File: 07/14/17/071417-02-1 Second Floor - Second Floor - Preliminary.dwg - 27/02/17 11:28 AM

Buchholz Architects
123 Columbia Turnpike Suite 204A
Florham Park, NJ 07932
973.746.0100 Phone
Info@buchholzgroup.com

BUILDING 78 | 78 JOHN MILLER WAY | KEARNY, NJ 07032

Date: 7-Feb-17 | Scale: NTS | Project Number: 0714-1577

NICK SHEARS
DIRECTOR OF LEASING
HUGO NEU REALTY MANAGEMENT LLC
O: (973) 771-6413 C: (609) 937-2564
FLEX SPACES @ KEARNY POINT

Drawing:
LP-206

